

# RT-1 V3 Roll Tray



## Features & Benefits

- 2:1 nesting ratio
- Reinforced bottom grid, corners and sidewalls
- Ergonomically designed sturdy handles for easy handling
- Smooth interior surfaces protect packaging
- Designed for blind, overhead stacking
- Four-way hand truck entry
- Merchandise from front or rear
- View product from all four sides
- Material: FDA approved food grade polyethylene provides strength and durability needed for multiple applications

## Options

- Colors: Choice of standard or optional non-heavy metal (NHM) or FDA approved colors
- Decoration: Hot-stamp branded or molded-in logos
- Tracking: Bar code labels or RFID tags available to integrate with Rehrig technology offering

Specifications	IN/LB	CM/KG
Overall Length (L)	25.88	65.74
Overall Width (W)	21.50	54.61
Overall Height (H)	3.47	8.80
Interior Length	24.55	62.36
Interior Width	20.63	52.39
Product Clearance	2.59	6.58
Nest Increment	1.50	3.81
Stack Increment	2.97	7.53
Weight	3.30	1.50
48' Trailer Quantity	5,280	
53' Trailer Quantity	5,808	
20' Trailer Quantity	1,584	

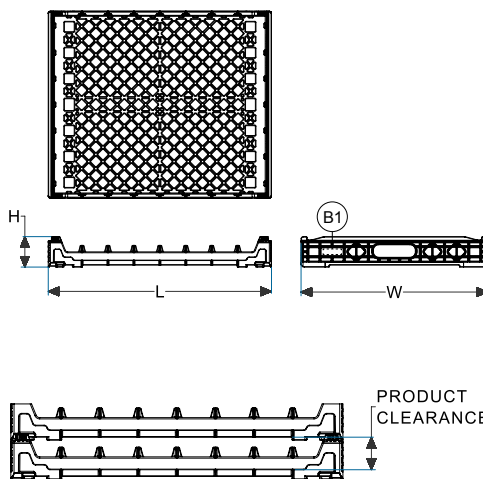

Branding Area	WIDTH (IN)	HEIGHT (IN)
Brand (B1)	2.25	0.625

**Corporate Headquarters**  
 4010 East 26th St., Los Angeles, CA 90058  
 (800) 421-6244 • (323) 262-5145

**Locations**  
 Los Angeles, CA • Orlando, FL • Atlanta, GA • De Soto, KS  
 Erie, PA • Dallas, TX • Kenosha, WI • Querétaro, Qro., Mexico

**Web:** [www.rehrigpacific.com](http://www.rehrigpacific.com)



A FAMILY TRADITION OF GROWTH, SERVICE AND INNOVATION