

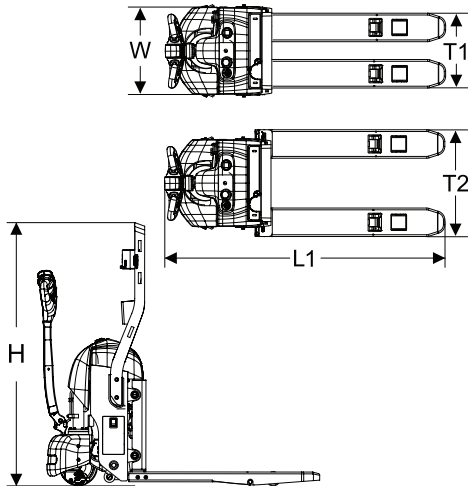

Features & Benefits

- Industry first adjustable tine span system expands and retracts for large and small format stores
- Utilizes durable industry standard components to transport full and half pallets from trailer to store or cooler
- Powerful 48V drive system to handle heavy pallet loads and steep inclines
- 4000lb max load capacity to accommodate full size 40"x48" plastic and wood pallets
- Highly maneuverable with a zero-turn radius and ergonomic upright controls
- Turtle mode to limit the speed for improved control in tight spaces
- Compact chassis design to maneuver through narrow store aisles and into coolers
- Smart enablement capability includes RFID reading, pallet asset tracking, GPS location, critical diagnostics, preventative maintenance alerts and more
- Lightweight 30Ah lithium-ion battery easily lasts a full shift with tool-less quick swapping when necessary
- Battery fully charges in approximately 3 hours; battery can be charged when installed in the lift or when removed
- Button to disable electromagnetic brake and allow lift to be manually pushed or pulled
- Durable and robust serviceable components for easy maintenance
- Retracting load belt and backrest with E-track slots for securing pallet load
- Compatible with Duo pallets and most full-size plastic and wood pallets

Duo Short Tine



Duo Long Tine

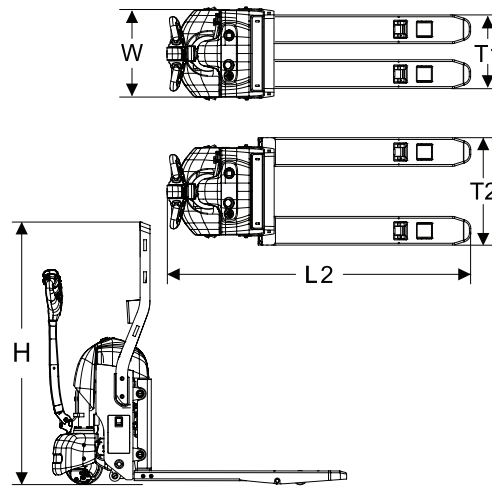

SPECIFICATIONS	IN/LB	MM/KG
Length - Short Tine (L1)	60	1524
Length - Long Tine (L2)	65	1651
Chassis Width (W)	20	508
Narrow Tine Span (T1)	14.6	370
Wide Tine Span (T2)	23.6	600
Height (H)	58	1473
Weight - Short Tine	590	267
Weight - Long Tine	630	285
Load Capacity	4000	1800